



OPERATING MANUAL

DIESEL GENERATOR OPERATING MANUAL

KOCSAN FACTORY & SERVICE

Sanayi Mah. İzmit Sanayi Sitesi, 13.Cadde,
313.Blok No:24-26, İzmit- KOCAELİ / TÜRKİYE

Phone: +90 (262) 321 93 93

Fax: +90 (262) 322 88 54

www.kocaelijenerator.com.tr

info@kocaelijenerator.com.tr

CONTENTS

1. INTRODUCTION	1
2. IDENTIFICATIONS	2
2.1 Air Filter	2
2.2 Air-Cooled Engine	2
2.3 Alternating Current	2
2.4 Alternator	2
2.5 Continuous Power	2
2.6 Standby Power	2
2.7 Decibel (dB)	2
2.8 Star Connection	2
2.9 Four Stroke Engine	2
2.10 Frequency	3
2.11 Fuel Injector	3
2.12 Governor	3
2.13 Fuel Pump	3
2.14 Kilowatts	3
2.15 Water Cooled Engine	3
2.16 Spare Power	3
2.17 Voltage Regulator	3
2.18 Star Connection	3
3. WARNING SIGNS	4
4. SECURITY INSTRUCTIONS	5
4.1 Warning and Safety Instructions	5
4.2 First Aid Warnings against Electrical Shocks	7
4.2.1 <i>Opening the Respiratory Track</i>	7
4.2.2 <i>Breathing</i>	7
4.2.3 <i>Blood Circulation</i>	7
4.2.4 <i>If Can't Breathe but Have a Pulse</i>	7
4.2.5 <i>If Can't Breathe but Have a Pulse</i>	8
4.2.6 <i>Recovery Position</i>	8
4.2.7 <i>Warnings</i>	8
5. REPLACING THE GENERATOR	9
5.1 Lifting Down the Set	9
5.2 Moving the Set to its Place	9
5.3 Running, Installation and Commissioning of the Generator	9
6. ASSEMBLY, START and LOAD	10
6.1 Assembly	10
6.2 Cable Sections that Should be Used	11
6.3 Considerations when Loading the Generator	12
6.4 Air Required for Combustion	13

6.5 Extraction of Suction Air Outside the Room ..	13
6.6 Intake of Suction Air Inside the Room	13
6.7 Altitude Above Sea Level	14
6.8 Diesel System.....	14
6.9 Exhaust and Muffler System.....	14
7. GENERATOR SET DEFINITION	17
7.1 Fuel	17
7.2 Oil	17
7.3 Antifreeze	17
7.4 Generator Set Definition	17
8. TROUBLE SHOOTING	19
9. GENSET CONTROL PANEL	23
9.1 D-300	23
10. CUSTOMER RESPONSIBILITIES	26
10.1 Customer Responsibilities	27
11. CHECKS AND PERIODIC MAINTENANCE	29
11.1 Pre-Startup Controls	29
11.2 After Startup Controls	29
11.3 Periodic Maintenance to be Performed	30
11.3.1 First Maintenance (50 Hours)	30
11.3.2 6 Months or "250 Hours" Maintenance	30
11.3.3 Annually or "750 Hours" Maintenance	30
11.3.4 Every "1250 Hours" Maintenance	31
11.3.5 Every "2500 Hours" Maintenance	31
12. TERMS OF WARRANTY	32
13. EXCLUSIONS FROM WARRANTY	33
14. CERTIFICATES	35

1. INTRODUCTION

Your generator has been meticulously carried out at every stage of production, process control, tests and final quality controls. The generator is guaranteed for 2 (two) years under the conditions specified in the Warranty Certificate within the scope of the use in accordance with the issues specified in the Operation and Maintenance booklet.

This booklet contains the information you need to start and maintain your generator and therefore to make efficient use of your generator for many years.

If you want to get a good performance from your generator and benefit from it for many years, you need to do exactly the operations described in the "Maintenance" and "Placement of Your Generator" sections.

Apart from our company and services, never have your generator repaired by unlicensed repairers. If your generator is within the warranty limits, you may be prevented from benefiting from the warranty. Likewise, any modification of the generator without the approval of the manufacturer or repairs and parts changes resulting from the use of non-original parts are excluded from the warranty.

We thank you for choosing us by purchasing our product and wish you endless benefit for many years. Our company reserves the right to make changes to the above technical tables without notice.





 Kocsan [®] Jeneratör Reliable Energy Solutions		KOCAELİ JENERATÖR ELEK. MAK. SAN. TİC. LTD. ŞTİ. Sanayi Mah., İzmit Sanayi Sitesi, 13.Cad., 313.Blok, No:24-26 İzmit / KOCAELİ / TÜRKİYE Tel : +90 (262) 321 93 93 info@kocaelijenerator.com.tr - www.kocaelijenerator.com.tr	
JENERATÖR MODEL GENSET MODEL		JENERATÖR SERİ NO GENSET SERIAL NUMBER	
MOTOR MARKA ENGINE BRAND		ALTERNATÖR MARKA ALTERNATOR BRAND	
STANDBY GÖRÜNÜR GÜÇ STANDBY APPARENT POWER		PRIME GÖRÜNÜR GÜÇ PRIME APPARENT POWER	
STANDBY AKTİF GÜÇ STANDBY ACTIVE POWER		PRIME AKTİF GÜÇ PRIME ACTIVE POWER	
GERİLİM VOLTAGE		ÜRETİM YILI PRODUCTION YEAR	
FREKANS FREQUENCY		YAKIT TANKI KAPASİTESİ FUEL TANK CAPACITY	
GÜÇ FAKTÖRÜ <i>cosφ</i> POWER FACTOR		AĞIRLIK WEIGHT	
HIZ SPEED		EBAT (LxWxH) DIMENSION	
			
		 Made in TURKEY	

Figure 1.1: KOCSAN Generator Group Label

2. IDENTIFICATIONS

- 2.1 Air Filter:** It is a device that filters the incoming combustion air before the combustion chamber. It is a very important factor that affects the life of a diesel engine. KOCOSAN uses high quality filters in the products it uses.
- 2.2 Air Cooled Motor:** It is the cooling form of the air moved with the help of the fan or the propeller placed on the rotating parts of the engine by moving on the heated parts of the engine.
- 2.3 Alternating Current:** Alternating current is used in most homes and workplaces. Alternating current is defined as current with both positive and negative values whose current direction changes regularly. The frequency of this change of direction is fixed on a per-second basis and is used as 60 Hz in the USA and 50 Hz in Europe and in our country.
- 2.4 Alternator:** It is an electromechanical device that converts mechanical energy into electrical energy with alternating current. Our generators use brushless, synchronous top-quality alternators.
- 2.5 Continuous Power:** It is the power recommended by the manufacturer in operation in accordance with the continuous operating conditions (which is always described as operation at constant and unchanging load). The generator is suitable for continuous, uninterrupted operation at full load.
- 2.6 Standby Power:** The power obtained by resting the generator after running it for a certain period of time and leaving it to cool, and by restarting the cooled generator. Standby power is approximately 1.1 times continuous power.
For example; The standby power of the generator is expressed as 110KVA with a continuous power of 100 KVA
- 2.7 Decibel (dB):** One tenth of the unit that shows the sound intensity. Since the difference between the limits of the ear in terms of sound intensity is quite large, logarithmic consonant, ie decibel, is used in practice rather than arithmetic sound intensity. Decibel is denoted by "db". The name Decibel originated from the name of Alexander Graham Bell, the inventor of the telephone. Desi means one-tenth, and the waist comes from the surname BELL. The maximum sound level that the human ear can tolerate is 140 dB.
- 2.8 Triangular Connection:** It is the connection of three-phase generators to form their phases in a triangular way. When two phases are used to obtain 120/240 V from three-phase systems, the power is reduced to 1/3.
- 2.9 Four-Stroke Engine:** Internal combustion engines need to make four separate movements in order to complete a power cycle.
- The mixture of fuel and air fills with the movement of the piston outwards.
 - The mixture is compacted by moving the piston inside.
 - In gasoline engines, the stuck mixture is ignited by a spark, while in diesel engines it spontaneously ignites and combustion occurs under high pressure and temperature. With the energy released as a result of combustion, the piston is pushed outwards. In this way, the crankshaft is rotated and kinetic energy is obtained.

- d. During the return of the piston, the exhaust valve is open and exhaust gases are discharged from the piston. The cycle thus takes the starting position, and from stage 1 onwards, the operations are repeated.
- 2.10 Frequency:** The number of fluctuations in alternating voltage or current that occur over a period of time. The fluctuation that occurs per second is also called Hz.
- 2.11 Fuel Injector:** It is the part that sprays fuel in a measured amount into the combustion chamber.
- 2.12 Governor:** A system that detects the speed of the actual motion provider by means of a magnetic receiver or by following the frequency at the generator output. In line with the engine speed, it ensures the appropriate amount of fuel to be delivered to the combustion chambers through the electric control system in order to provide the required speed.
- 2.13 Fuel Pump:** It is the device that measures the fuel and sends it to the injectors in a pressurized manner.
- 2.14 Kilowatt:** It is the actual electrical power of 1000 Watts.
- 2.15 Water Cooled Engine:** It is the type of engine that is cooled by water circulating in the heated places of the engine. Coolant water goes to the radiator, cools down with the help of the propeller in the radiator and again goes to the engine, and this process repeats.
- 2.16 Spare Power:** Power to be activated in case of need. When the actual power provider is deactivated, it is the power source chosen to generate electrical energy. The kW outputs of the generators selected for backup power applications are higher than those of continuous application generators.
- 2.17 Voltage Regulator:** The Voltage Regulator is the device that ensures that the voltage obtained from the generator is automatically kept at the desired values inside or outside the system.
- 2.18 Star Connection:** It is a method of connecting the phases of the three-phase generator in a Y shape between themselves. One end of each phase will come into contact with each other and the other ends will be connected to the appropriate lines to be consumed.

3. WARNING SIGNS



Do not approach the Rotating Parts! Protect your body and clothing from rotating parts



Radiator air discharge. The radiator violently expels air.



Do Not Touch Hot Surfaces! When you touch hot surfaces, your body is damaged



Attention!
Can throw hot water from the radiator



Danger! High Voltage



Never remove the protectors of moving parts



Use Diesel Fuel



Be sure to read the user manual before using the generator



Attention



After removing the gap, squeeze half a turn with the key



Electric Shock Hazard



Tighten the drain plugs before filling the radiator water



Grounding point. Be sure to do product grounding



Do not approach with fire



Places to lift the generator. Do not attempt to lift the generator except where the sign is present. Otherwise, the product may fall off during lifting and its surroundings and the product may be damaged



Battery



Emergency Stop



Attention! Do not touch any part of the product without reading the operational manual

4. SECURITY INSTRUCTIONS

4.1 Warnings and Safety Instructions

! If there is any point in the user manual that you do not understand or doubt, please contact our technical team at our contact numbers. Our technical team will make the necessary explanations to you.

! Read the manual supplied with the generator set carefully.

! Every change you make to the engine, alternator, control panel and additional equipment requires the approval of the manufacturer. Otherwise, our warranty ends.

! Do not smoke while filling the fuel tank.

! Wipe the spilled diesel, oil and water and do not leave the wet cloths around, but remove them in a suitable place and then throw them in the trash properly.

! Avoid refueling when the engine is running.

! Never lubricate, clean, maintain or adjust the engine in working condition.

! Exhaust gases are harmful and lethal to human health. Be careful to place the engine to prevent the accumulation of toxic gases. Exhaust fumes must be transported to the open environment with the help of spiral pipes. These transactions are not the responsibility of our company.

! Alert people near the generator during start-up.

! When dealing with the generator, do not wear clothes with dangling arms, etc., and do not approach the working machine. When the engine is running, the propeller blades may not be clearly visible.

! Never operate your generator set without protective equipment and the rotating parts being enclosed.

! Do not open the radiator cover when the engine is hot. Do not put water on the engine that is running.

! Never put seawater, stream water, other electrolytes or corrosive substances in the cooling system.

! Never approach the battery with bare fire. Because electrolyte gases are flammable (usually when charging the battery). In addition, their acids are dangerous for the skin and eyes.

! The generator set must be under the supervision of only one person.

! The generator set must always be controlled from the control panel.

! If your skin is irritated by exposure to high-pressure fuel contact, consult a doctor immediately.

! Diesel fuel can cause skin allergies in some people. Use protective gloves or hand cream.

! Before starting repairs or maintenance, put the generator in the closed position, lower the relevant fuses, remove the battery pole head in order to prevent accidental operation of the engine.

! Never use petroleum or other flammable materials to clean parts. Use only recommended cleaning agents.

! Use only the parts recommended by KOCSAN Generator.

! Make electrical connections according to standards.

! Do not use connection cables that are damaged, not well insulated, or damaged.

! The glycol in the antifreeze is toxic and dangerous if ingested. Avoid contact with your skin and eyes.

! Hot oil or water causes severe skin burns. Avoid hot oil contact with your skin. Before starting any operation, make sure that the system is not under high pressure.

! Never change the positive and negative poles on the battery. Any changes on the poles can cause serious damage to the electrical system. See the electrical diagram.

! Use the lifting hooks to lift the generator set. Check that the lifting equipment and the lifting closure are sufficient.

! Different equipment mounted on the generator set causes the center of gravity to change its location. Special means of transport may be needed to ensure stability and safe working conditions.

! Never apply any operation to the generator set that has been removed with the lifting tool.

! The generator set should never be operated in areas where products containing explosives are present. All electrical equipment is covered with a protective layer, it can be affected by sparks.

! Always use the recommended and dehydrated fuels. The use of low-quality fuel will damage the diesel pump, which will lead to debilitation of the engine and mechanical failures, which can lead to non-warranty due.

! Never use high-pressure cleaners to clean the engine and its equipment. Radiators, flexible pipes, electrical equipment, etc. can be damaged.

! Even when the generator set is installed in a room with a ventilation system in good condition, extra fire extinguishers should be available as a precaution against fire.

! If the connection of the generator set to the panel is made by your company, this must be done by an authorized and qualified electrician with written approval from our company. Otherwise, the responsibility belongs to your company and the product will be out of warranty.

! The grounding of the generator set must be carried out properly. The grounding process is the responsibility of the person or company purchasing the set. For this, you can use the grounding

bolt on the chassis.

! When making an electrical connection or operation, always stop the set and take the necessary precautions to prevent it from working as mentioned above.

! If the electrical installation is laid by your company, use durable and flexible cables insulated with rubber. Cable sections are specified in Table 6.3.

4.2 First Aid Warnings Against Electrical Shocks

! Do not touch the person exposed to electric shock with bare hands before disabling the electrical source.

! If possible, disable the electrical supply.

! If this is not possible, unplug the power or remove the power cord from the person exposed to the electricity.

! If these are also not possible, dwell on the dry insulating material and remove the person exposed to the electricity from the conductor, preferably using an insulating agent such as dry wood.

! If the victim is breathing, bring the victim to the recovery position as described below.

! If the person exposed to electricity has lost consciousness, perform the following procedures to sober up:

4.2.1 Opening the Respiratory Tract

- Tilt the victim's head back and raise his chin up.
- Remove objects such as dentures, chewing gum, cigarettes that may have escaped into the victim's mouth or throat.



4.2.2 Breathing

- Check whether the victim is breathing by seeing, listening and feeling.

4.2.3 Blood Circulation

- Check the pulse of the victim's neck.

4.2.4 If Can't Breathe but Have a Pulse

- Close the victim's nose tightly.
- Breathe deeply and connect your lips with the victim's lips. Blow slowly through the mouth, observing that the rib cage is rising. Then stop blowing and let the rib cage descend completely. Exhale to the victim an average of 10 times per minute.

- If the victim is to be left alone to call for help, return quickly by exhaling 10 times and continue the exhalation.
- Check the pulse after every 10 exhalations.
- As soon as he starts to breathe, bring the victim to a recovery position.

4.2.5 If Can't Breathe and No Pulse

- Seek medical help or call your nearest health care provider.
- Exhale twice to the victim and begin the heart massage as follows.
- Place the palm 2 fingers above the junction of the rib cage.
- Place your other hand with your fingers locked
- Keeping your arms upright, press down 4-5 cm 15 times per minute. Repeat 2 exhalations and 15 heart massages until medical help arrives.
- If the victim's condition improves, continue exhaling by checking his pulse. Check your pulse after every 10 exhalations.
- As soon as he starts to breathe, bring the victim to the recovery position.



4.2.6 Recovery Position

- Lay the victim on his side.
 - Hold the head tilted with the jaw facing forward to ensure that the airway is open
 - Ensure that the victim does not roll forward or backward
- Check his breathing and pulse regularly. If either stop, repeat the above procedures.

4.2.7 Warnings

! Until the victim regains consciousness; Do not give liquids such as water.

5. REPLACING THE GENERATOR

5.1 Lifting down the kit

Take the following precautions for maximum safety when unloading your generator set from the transport vehicle.

- The devices and ropes you use to remove them must be of appropriate capacity.
- Lifting ropes must be attached to the specified lifting places on the generator.

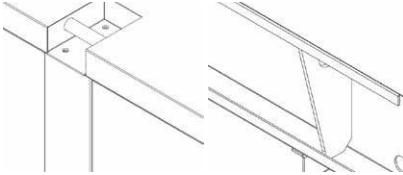

Figure 5.1: Generator Lifting Places

- During lifting, the clearance of the ropes should be gently removed and it should be ensured that it does not damage any parts on the embankment or, if there is a cabinet, the cabinet.
- If using a forklift, the forks must be long enough to accommodate both side sleepers of the chassis. During the movement of the forklift, the set should be moved as close to the ground as possible.
- The floor must be strong enough to support the weight of the generator set. Otherwise, measures should be taken to spread the weight.
- The set should be lowered to the place closest to the point where it will serve.

5.2 Moving the Set to its Place

If the set cannot be lowered by forklift or crane to the point where it is to be operated, then pallet trucks with the appropriate capacity should be used for short-distance displacements. If this is not possible, the generator set can be placed in place by lowering it onto pipes of a wider and equal diameter than the chassis, and then pushing it so as not to cause damage.

Attention!

These operations can only be carried out on flat floors. The floor on which the set will be placed must be pre-pre-wired and reinforced according to the set weight.

5.3 Generator Operation, Installation and Commissioning Preparation

In order for the generator set to serve well, it is necessary to follow certain rules during its installation. If these rules are not followed, the set may be damaged or wear may occur in a

shorter time than normal. Visually inspect the generator assembly before starting. Check for any fractures, cracks, breaks, oil and diesel leakage anywhere, and do not start the generator without remedying the fault. Check that the electrical wiring connections are made correctly. Check for foreign objects such as switches, tools, tops, paper, etc. on the engine and alternator. The following points illustrate the principles that must be followed in the installation of a standard diesel generator. In case of special applications, please contact our technical team.

6. ASSEMBLY, START-UP and LOAD

Although the choice of the location of the generator varies from application to application, the following factors are the first points to consider.

1. The place should be free from dry dust, airy and bright
2. Diesel replenishment
3. The condition of the floor
4. Ease of entry and exit to the location of the set
5. Suitable air intake
6. Convenient exhaust outlet
7. Convenient hot air outlet
8. Noise level
9. Proximity to the customer dashboard
10. Protection grounding should be done

6.1 Assembly

If the installation of the generator is not done by our company or authorized services, the product is not covered by the warranty. Be sure to install the generator to our authorized service or company. If the generator installation is done by your company, the following points should be considered.

- The location of the generator should be suitable for dismantling the engine and alternator without loss of time and labor, and there should be no materials or objects on the exit path that prevent these components from being removed from the room.
- No changes should be made to the lifting places on the generator as it may be necessary to completely disassemble the unit over time
- Diesel pump, injectors and diesel filters must be easily accessible in terms of both replacement and removal of diesel air.
- If there is a mark on the flywheel for the pump to be set, it should be ensured that it is easily seen
- The cylinder head, rocker cover and other parts of the valve mechanism must be able to be removed without having to dislodge the engine
- The oil filler cap / drain plug and oil dipstick must be easily accessible. See Figure 6.1.



Figure 6.1: Oil Drain Plug

- The water filler must be capped and easily accessible. See Figure 6.2

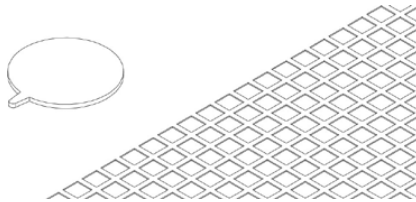

Figure 6.2: Water Filler Lid

- In order for the generator to perform its job properly, the connection to the enterprise must be made correctly. There are two cable entries to the board. One is the mains input for the control of the grid, the other is the generator output. The network line taken from the meter output or compensation board, if any, is given to the receiver via the network contactor. The point to be considered here; is the connection of the generator to the load after the meter.
- In order to cool, service and maintain the generator, it must be placed in place so that all the doors of the generator can be opened.
- Unauthorized persons must be prevented from entering the generator site.

6.2 Cable Sections that Should be Used

In some cases, the air to be sucked by the engine can be taken from outside due to the fact that the room where it is located is not available. In such cases, the following points should be considered

Generator Power (kVA)	Recommended Cable Section (NYY) mm
Between 15 – 16	4 x 4
Between 20 – 35	4 x 6
Between 40 – 55	4 x 10
Between 55 – 63	4 x 16
75	3 x 25 + 16
Between 110 – 150	3 x 50 + 25
Between 150-165	3 x 70 + 35
210	3 x 95 + 50
250	3 x 120 + 70
Between 320-350	2 x (3 x 70 + 35)
Between 400-450	2 x (3 x 95 + 50)
500	(3 x 95 + 50) + (3 x 120 + 70)
550	2 x (3 x 120 + 70)
Between 600-720	3 x (3 x 95 + 50)
Between 800-880	4 x (3 x 95 + 50)
1080	4 x (3 x 120 + 70)
1154	(3 x 120 + 70) + (3 x 150 + 70)
1443	4 x (3 x 180 + 95)

Table 6.3: Cable Section Table

6.3 Considerations When Loading the Generator

The generator must not be loaded above its capacity. Overloading causes an excessive voltage drop, which causes the devices in the circuit to work unhealthily or even to fail. Another point to be considered in loading is that the loading is balanced. Balanced loading means that the three phases draw equal current. You can observe this from the ammeters of three phases located on the board. Unevenly charged phases will heat up or even burn out, drawing in overcurrent.

Devices connected to the unevenly charged phase will also suffer. In order not to cause this, the single-phase (monaphase) loads in the enterprise should be evenly distributed to three phases.

6.4 Air Required for Combustion

It is recommended that the suction air temperature that the engine will use for combustion be less than 30 °C. If the air sucked is continuously higher than 30°C, there will be a decrease in engine power. The power ratings given to you for the engine are obtained as a result of tests under standard conditions. If the suction air of the engine is inevitably taken from a hot place, then the power value of the engine must be corrected.

6.5 Removal of Suction Air from Outside the Room

In some cases, the air to be sucked by the engine can be taken from outside due to the fact that the room where it is located is not available. In such cases, the following points should be considered.

- Care should be taken to ensure that the suction air is as clean as possible.
- Care must be taken to ensure that exhaust gases or hot air passing through the radiator are not reabsorbed.
- Care should be taken not to mix chemical impurities into the suction air. It should be ensured that the air intake site is designed and placed in such a way that it is not blocked by water, snow, dust and pollutants.
- There should be no sharp turns on the line.
- The pipe length should be kept as short as possible.
- The pipe diameter should not be smaller than the diameter of the air filter inlet.
- There should be no sharp elbows along the line.
- Pipe insides should be clean and smooth. If a hose is used along the line, it must be reinforced so that it does not shrink during suction.

On the other hand, care should be taken not to raise the temperature in the room above 60 ° C. Otherwise, the electrical components on the motor are more likely to fail. In cases where the temperature rises above 60°C, it is necessary to install a fan that sends fresh air to the room to lower the temperature. When making calculations about air consumption and temperature in the room, if there are devices that consume air or produce heat other than the generator, their consumption and contributions should also be taken into consideration.

6.6 Taking the Suction Air from the Room

If the suction air is taken from the room;

- Adequate air intake into the room must be guaranteed.
- The dimensions of the air intake place in the room should be such that they do not allow vacuum to form in the room. In addition to the suction air required for combustion, the engine fan also blows air out of the room. Therefore, in order to avoid vacuum, the air intake of the room should be opened as 1.5 times the radiator area.
- The air intake must be positioned in such a way that it is least affected by the temperature emanating from the exhaust and radiator.

- It is necessary to place the air suction in such a way that it is not accidentally blocked.

As mentioned earlier, since the temperature of the sucked air is important for engine performance, the level of heat from the exhaust and alternator is important. Therefore, insulation of exhaust pipes can be a measure that provides temperature control. If the suction air temperature rises to a critical level when the contributions of other devices that generate heat in the room are taken into consideration, then it is imperative to force ventilate the room with a fan. The generator group ventilation layout plan for the basement and ground floor is shown in Figure 6.4-6.5-6.6-6.7.

6.7 Elevation above the Sea Level

The diesel pumps of the engines are set in factories to give 100% power output at an air pressure equivalent to a column height of 760 mmHg. There is also a decrease in the engine power value, as the air pressure altitude varies in high altitudes (more power changes for naturally aspirated engines and less for turbocharged engines).

6.8 Diesel Oil System

In order for the motor to work properly, it is necessary to ensure a smooth and adequate flow in the diesel circuit. In this respect, it is important to replace diesel filters in a timely manner, to check the flex hoses from time to time. Breakages or crushes in the hoses that carry diesel to the pump can make diesel flow difficult, causing low yield or stopping. If the diesel tank is installed at a height, it will be useful to place a valve at the supply pump outlet for malfunctions.

On the other hand, since the diesel temperature above 35 ° C will cause a decrease in power in the engine, care should be taken to pass the diesel lines through hot zones (exhaust, hot air passing through the radiator, direct sunlight, etc.).

During group assembly, care should be taken to place the plugs used for the evacuation of water and deposits from the tank in a position where they can be easily reached and dismantled.

6.9 Exhaust and Muffler System

It is important that the generator group room is isolated in terms of temperature control. But it should be remembered that an application intended only for thermal insulation will have a negative effect on sound insulation.

The location of the silencer on the exhaust lines has a significant effect in terms of sound insulation. In this respect, the best result is obtained when the tailpipe of the silencer is close to the outlet. To achieve the best sound insulation effect, reduce the length of the exhaust pipe after the muffler to 0.8-1.5 mt. is between.

In practice, it is useful to place the silencer close to the exhaust outlet of the engine in cases where it cannot be placed close to the pipe outlet.

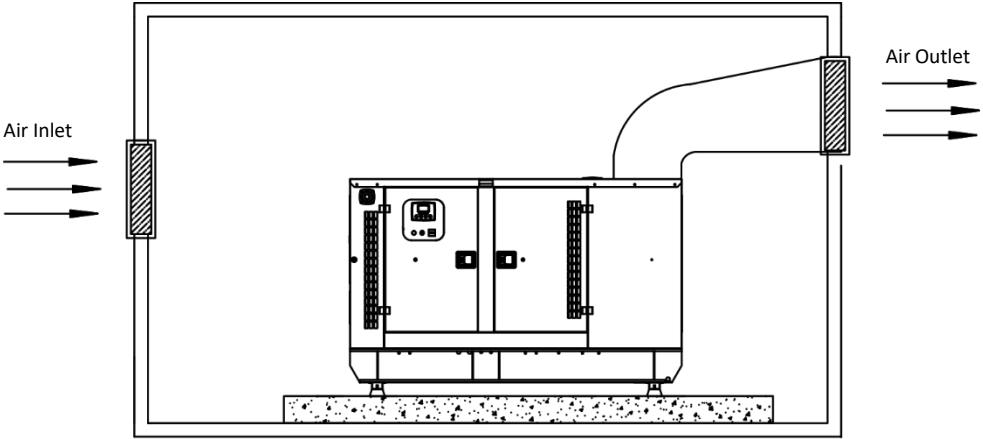

Figure 6.4: Ventilation Layout of Genset with Cabinet

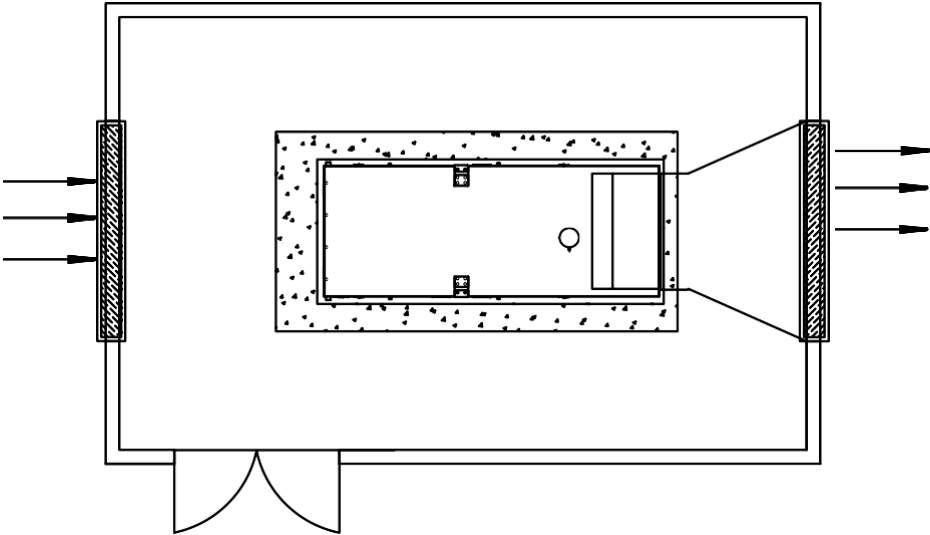

Figure 6.5: Ventilation Layout of Genset without Cabinet

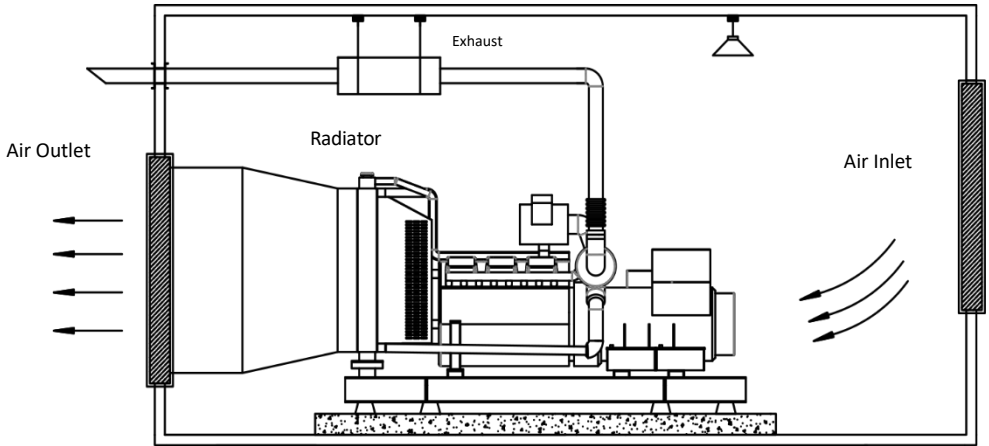

Figure 6.6: Ventilation Layout of Genset without Cabinet

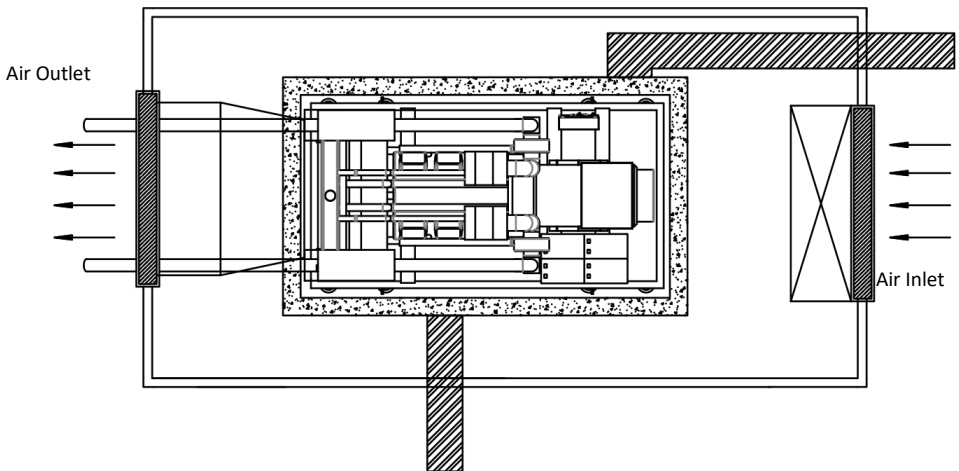

Figure 6.7: Ventilation Layout of Genset without Cabine

7. DESCRIPTION OF THE GENERATOR SET

7.1 Fuel

The manufacturers of the diesel engines used by KOCSAN Generator require that the diesel used is in accordance with ASTM D-975-77-2D or BSEN590: 1995 CLASS 1 Quality.

7.2 Oil

Viscosity-Temperature Diagram: To ensure that the oil used is compatible with the temperatures in your area Figure 7.1. You can check from the chart.

7.3 Antifreeze

Your set's radiator has not been fitted with antifreeze at the factory exit. When putting water in your radiator, antifreeze should be placed at least 35%. Using water with summer and winter antifreeze in your engine is of great importance for the life of your engine and water channels.

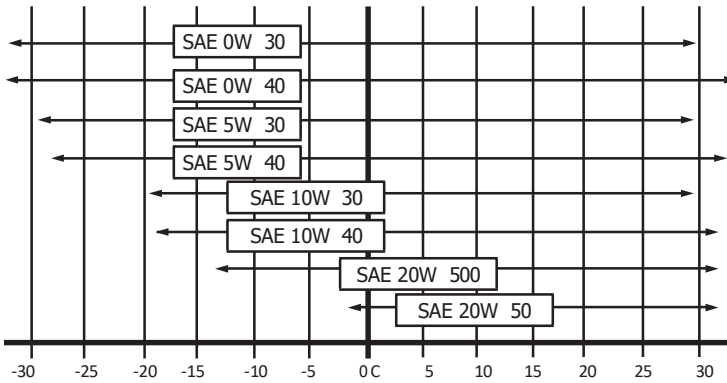
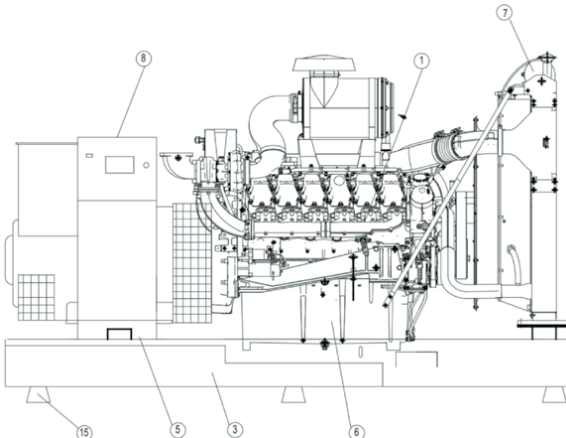
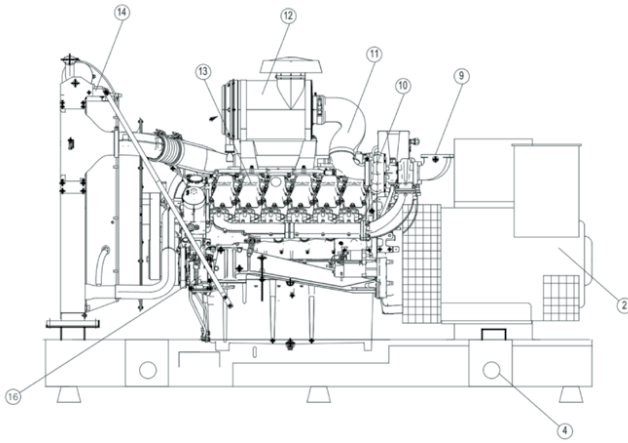

Figure 7.1. Compatibility Chart of the Oil Used

7.4 Generator Set Description

The service life of the generator set as reported by the ministry is 10 years. KOCSAN Generator set and all the equipment in the content of the generator are listed below.





1	Diesel Motor	9	Exhaust Pipe Outlet
2	Alternator	10	Turbocharge
3	Fuel Tank	11	Air Suction Pipe
4	Frame Lift Sheet	12	Air Filter
5	Cable Inlet (with TMCB)	13	Engine Cylinders
6	Engine Oil Crankcase	14	Radiator
7	Expansion Tank	15	Rubber Wedges
8	Control Panel	16	Charging Alternator

8. TROUBLESHOOTING

The generator is running even though the network is not interrupted, or the generator continues to work even though it arrives:

-The motor body must be grounded, check. -Mains voltages may be out of the programmed limits, measure the phase voltages.

-Press MENU to check that the device measures the mains voltages correctly.

-The lower and upper voltage limits of the network may be given too narrowly. Switch to the program mode and check the "Mains Voltage Lower Limit" and "Mains Voltage Upper Limit" parameters. Standard values are 170 / 270 volts.

-The hysteresis voltage may be given too high. If the network is interrupted, the lower limit is raised by the hysteresis voltage, the upper limit is lowered by the hysteresis voltage. The standard hysteresis value is 8 volts.

AC voltages are read incorrectly in the device or generator frequency is read incorrectly:

-The motor body must be grounded, check it. Combine the battery (-) with the Neutral to see if the error has been corrected.

-Read error +/- 3 volts. -If there are incorrect measurements only when the engine is running, there may be a charging alternator or conjunctor failure in the engine. Unplug the charging alternator and try again. -If there are incorrect measurements only when there is a network, the battery charge rectifier may be faulty. Check the rectifier insurance by turning it off.

Phase-neutral voltages are read correctly, but phase-to-phase voltages are not:

-The phase sequence is incorrect, please correct it.

-The current transformers are not connected to the respective phases or some of the current transformers are connected in reverse directions. Connect one current transformer to the device at a time and determine the ends so that the correct KW and $\cos\Phi$ are measured, and when they are all complete, connect all three. NOTICE: Short-circuit the outputs of current transformers that you are not using.

The engine does not start on the first start, then does not press the starter, and there is OIL PRESSURE! The message comes out:

-The oil pressure line closes too late, when the ignition is closed, the starter will be pressed. If desired, the oil pressure monitor can be changed.

When the mains is interrupted, the device turns on the contact, does not press the starter and there is OIL PRESSURE! The message comes out:

-The BATTERY (-) does not come to the oil pressure input of the device.

-The oil pressure tip may be left idle.

-The oil may be broken in the pressure cable.

-The oil pressure gauge may be defective.

-The oil pressure may be closing the joint too late, the starter will be pressed when the ignition is closed. If desired, the oil pressure monitor can be changed.

When the network is interrupted, the motor starts, but the device subsequently gives a STARTER error and the motor stops:

-Generator phase voltage does not come to the device. Measure the voltage between the generator L1 phase and the generator neutral ends while the motor is running. The generator phase fuse may have been blown or turned off, there may be a connection error. If everything is OK, turn off all the fuses on the board, then turn them all on, starting with the DC supply fuse, and test again.

The device cuts the starter late:

The alternator voltage rises late, and the alternator's remenance voltage is below 20 volts. The device interrupts the starter with the generator frequency and needs at least 20 volts to be able to read the frequency. If the problem is absolutely to be solved, the only way is to add a relay. The coil of this relay will be between the BATTERY (-) and the D+ (lamp) end of the charging alternator. The starting output of the device must be passed in series through the normally closed contact of this relay. Thus, when the charging alternator generates voltage, the starter is interrupted.

The device does not work at all:

Measure the DC voltage between the BATTERY+ and the battery-terminal blocks on the back of the device. If there is voltage, turn off all the fuses on the switchboard, then turn them all on, starting with the DC supply fuse, and test again.

Unable to enter programming position:

PROGRAM DISCONNECT THE BATTERY (-) from the lock end. After the process is finished, please redo this connection to prevent unauthorized program changes.

The AUTO light is flashing, the generator does not work even though the mains is cut off:

You are on a weekly work schedule OFF time. Please check the date and time setting of the device and the parameters of the weekly work schedule.

<p>Engine can not to start</p>	<p>a) Weak or non-charged battery. b) Reverse or bad battery connection. c) Fuses on the control panel are waste. d) The emergency stop button is pressed. e) One of the fault leds is lit, so there is a fault. f) The control panel is in the closed position.</p>	<p>a) Have the battery charged or replaced b) Check the connections Remove the fuse c) Turn the emergency stop switch to the right and turn it on d) You need to fix the malfunction e) Move the control panel switch to the auto position</p>
<p>Engine can start however can not run</p>	<p>a) Solenoid does not work b) Poor quality diesel oil c) Diesel tank is empty d) There is air in the diesel system e) Air filter closed</p>	<p>a) Control the energy b) Replace fuel c) Add diesel d) Deaerate the engine e) Clean or replace the air filter</p>
<p>The alternator does not produce nominal voltage at idle.</p>	<p>a) Auxiliary fuse on the regulator waste b) Rotary diodes are broken c) The speed of the engine is very low d) The regulator board is faulty</p>	<p>a) Replace the fuse b) Check the diodes with a 4.5 V battery and a lamp connected to it in series. The lamp should not burn in one direction and not light up in the other. If it is corrupted, replace it c) Bring the engine speed to 1500 d) Replace the regulator</p>
<p>The alternator can not produce voltage</p>	<p>Voltage loss</p>	<p>a) The remenant voltage between the phases is sufficient to be 10% of the nominal voltage to produce the alternator rated voltage. b) Correct any disconnection or contactlessness.</p>

The generator voltage is too high.	<ul style="list-style-type: none"> a) One of the phase ends coming to the regulator is broken. b) The Regulator Board is faulty. 	<ul style="list-style-type: none"> a) Check the leads from the U-V-W terminal at the output terminal to the regulator. b) Replace the regulator board.
Vibrating voltage	a) The stability setting of the regulator is broken	a) Set from the trimport located on the regulator.
The voltage between the phases is unstable.	a) Excessive unstable load	a) Balance your mains loads.
There is voltage but TMCB is tripped	<ul style="list-style-type: none"> a) There is a short circuit in the installation b) The load is excessive 	<ul style="list-style-type: none"> a) Check the installation b) Adjust the load according to the current written on the group label.
Generator stops suddenly	<ul style="list-style-type: none"> a) Low oil pressure failure. b) High engine temperature. c) Diesel is finished. d) Starter failure. e) Check the fuses at the entrance to the control board. f) The engine does not start regularly. g) Overspeed failure. h) The control panel is in the closed position. i) The emergency stop button is pressed 	<ul style="list-style-type: none"> a) Check the oil level, add oil if it is necessary. b) Check the air inlet and outlet of the generator room. c) Add diesel to the tank. d) Reset the control panel, move it to the automatic position. e) Remove the fuse. If it still does, call the service call for service. f) Reset the machine, if it continues, call for service. g) Check the oil level and type, call for service. h) Move the control panel switch to its automatic position. i) Open the button.

9. GENERATOR CONTROL PANELS

D-300

The D-300 is a low-cost generator controller ready for remote monitoring.



D-300 Generator Control Unit

9.1.1 Properties

- Diesel and gas generator support
- 400Hz generator support
- 400xmeter-valued event log
- Commutable parameters from the panel
- 3-level program password
- 128x64 pixel graphic LCD
- Language loading
- Current-voltage sinus shape Current-voltage harmonic analysis
- 16 Amp/250V MC/GC outputs
- Programmable 6 digital outputs
- Programmable 3 analog inputs
- CANBUS-J1939 & MPU input
- 3 programmed service alarms
- Multiple automated test programs
- Weekly working schedule
- Dual generator support, equal aging
- Fine speed regulation (some ECU's)
- Automatic fuel pump control
- Protections cancelation feature
- Overpower protection
- Free configuration service
- Modem diagnostics page
- Parameter setting via USB, RS-232 and GPRS
- Possibility of control via SMS
- Ready for centralized monitoring
- Mobile generator support
- Automatic GSM geolocation
- GPS connection (RS 232)
- Uploading software via USB
- IP65 protection (with gasket)
- Reverse power protection
- Overcurrent IDMT protection
- Load shedding, dummy load
- Multiple load shedding programs
- Current imbalance protection
- Voltage imbalance protection
- Fuel recharge and fuel theft alarms
- Battery-supported real-time clock
- Idle speed control
- Battery charging operation
- Battle mode support
- Multiple nominal requirement definitions

- Contactor+motor switch driver
- 4 quarter energy meters
- Mains energy meters
- Fuel filling counter
- Fuel consumption counter

9.1.2 Measurements

- Mains and gen. FN - FF voltages
- Mains and generator frequency
- Mains and generator phase currents
- Mains and generator neutral currents
- Mains and generator, phase and total kW, kVA, kVAR, $\cos \phi$
- Engine speed
- Battery voltage

9.1.3 Communication

- 4-band GPRS modem (optional)
- USB Device
- RS-232 (2400-57600baud)
- J1939-CANBUS
- Locating over GSM
- GPS connection (RS-232)
- Central monitoring over the internet
- Sending SMS message
- E-mail sending
- Free software: Rainbow Plus
- Modbus RTU

9.1.4 Functions

- AMF device
- ATS device
- Remote starting device
- Manuel starting device
- Engine control device
- Remote monitoring panel

10. CUSTOMER RESPONSIBILITIES

Dear KOCSAN GENERATOR User,

Please pay attention to the following points in order to ensure that your generator is not out of warranty before its duration, runs smoothly and has a long life.

1. Transactions made when the warranty certificate or invoice is not presented will not be covered by the warranty.
2. Failures that may arise due to the intervention of 3rd parties, except for the persons or services personally authorized by KOCSAN to the generator group, are not covered by the warranty.
3. The controls and maintenance specified in the periodic maintenance schedule should be carried out in a timely and complete manner. Malfunctions that may arise due to lack of periodic maintenance are not guaranteed.
4. Installation of your generator must be carried out as specified in the instruction manual. Problems that will occur if not done will not be covered by the warranty.
5. The customer will be responsible for the malfunctions that may arise in case of using dirty and aqueous diesel.
6. The choice of oil for the engine should be as indicated in the instruction manual. Otherwise, malfunctions that may occur are not covered by the warranty.
7. Batteries are not guaranteed in case of breakage, excess acid deposit, leaving without charge and hardening.
8. In manual generators, the starter key should not be left immediately after the engine starts. If the engine is not starting, the starting process should not be done more than 3 times and 10 seconds each. Otherwise, the starting gear may break or the starter may burn out. These cases are not covered by the warranty.
9. Do not start or stop the diesel engine while the generator is under load. Starting and stopping should be done when the generator is idle after the load has been separated. Otherwise, jams may occur in the valves. It leads to malfunctions in the voltage regulator, transformers and diodes. These situations are out of warranty.
10. Our company is not responsible for the damages caused by overcurrent, low and high voltage that will occur in the network contactor used in automatic generators.
11. Do not disconnect the battery cables while the generator is running. Removing the battery cables for even a very short time can cause damage to the charging alternator relay and the electronic managing circuit. These situations are not covered by the warranty
12. Faults due to excessive or unbalanced load (such as alternator and contactor failures) are not covered by the warranty.
13. In manual mode, the generator is idle for 3-5 minutes to bring the engine to the operating temperature, and when the generator is stopped, it is first taken over the load and the engine is continued to run for 3-5 minutes without load to cool down. Otherwise, defects are out of warranty.
14. Defects caused by operating the group below 30% of its long-term prime power are not

covered by the warranty.

15. All our machines covered by the warranty must use original spare parts of the KOCSAN Generator. Defects that may occur if the original part is not used are not covered by the warranty.

16. The commissioning process of the purchased generators must be carried out by KOCSAN Generator Authorized Services. If the customer starts himself or in another service, it causes him to be out of warranty.

17. Additional equipment and projects cannot be made to the purchased generators within the warranty period other than the original equipment and project. Additional works planned to be carried out (parallel operation of generators, additional control unit, panel, transfer panel, etc.) If it is made without the approval of the KOCSAN Generator, the machine is out of warranty.

18. The warranty period is 2 years or 2000 hours (whichever occurs first) and starts on the date the generator is purchased.

10.1 Customer Responsibilities

1. The commissioning process, which is carried out by checking the working conditions of the machine (layout, installation, electrical connections, cable sections, ventilation, exhaust outlet, fuel path, etc.), is valid only for the point where the commissioning process is carried out. If the place where the first start process is carried out is to be changed, since the working conditions of the machine depending on the environment will also have changed, it should be checked and commissioned again by KOCSAN Generator Services in order to maintain the healthy operation of the machine and the warranty period. Relocation and re-commissioning by unauthorized persons will cause the machine to be out of warranty. The customer will bear the cost of the commissioning process for the second time.

2. All maintenance of all our generators within the warranty period, specified in the periodic maintenance schedule, must be carried out by the authorized services of KOCSAN Generator for a fee. The maintenance schedule and maintenance booklets of the generator were delivered to the customer by machine. In the event that the maintenance booklet and schedule in question are lost, the customer is obliged to provide these booklets again.

3. The customer shall bear the fee for the elimination of all maintenance, malfunctions and problems other than manufacturing defects.

4. In the case of on-board deliveries, it is the customer's sole responsibility to maintain the machine in appropriate conditions, including the responsibility for transport, the responsibility for unloading (after delivery on the truck until start-up).

5. If the purchased generator will not be commissioned within 2 months, it must be kept on hold, provided that the storage conditions of the generator in question are met. You can obtain the necessary information and assistance about the storage conditions of the machine in your hand from KOCSAN Generator Authorized Services.

6. The storage (canning) process of a machine within the warranty period must be made by KOCSAN Generator.

7. If the overtime work of the service personnel providing warranty service is requested by the customer, the customer will bear the cost arising from the overtime.

8. The fees for the purchase or connection of the entrances, barriers, walls, railings, ceilings or similar structures to reach the machine, rental cranes or the like, ramps or the like, tractors or protective structures, shall belong to the customer.
9. The customer has the right to ask and investigate the authority of the personnel who come for the service. This is also the customer's task.
10. In order to receive warranty service, the customer is obliged to show the machine's warranty certificate to the service authorities in order to receive warranty service. Therefore, the documents in question should be kept in an easily accessible place in the generator room.
11. The customer is obliged to ensure that the dimensions of the generator room comply with the norms, adequate ventilation and exhaust outlet.
12. KOCSAN Generator is not responsible for the failures that may arise from the drawing of more current than the rated current of the generator through the network contactor selected in accordance with the generator power.
13. In all our generators, the lower and upper limits of the network are determined on the basis of the values that our machine and the customer's enterprise can work healthily. Changing mains voltage limits customer If requested by the customer, this change can be made by writing a report that the customer has assumed all responsibility for the malfunctions that will arise from this change.

11. CONTROLS AND PERIODIC MAINTENANCE

11.1 Pre-Operation Controls

Your generator must be installed in accordance with the instructions and safety measures mentioned in the operating and maintenance manual.

Make sure that the electrical connections are made in accordance with the technical rules and schemes.

The following controls must be carried out in full at the first stage of operation of the generator set, and safety measures must be observed.

- Are there any scratches, fractures and similar damage to the metal parts of the generator, indicators?
- Is the generator properly and conveniently placed on a floor?
- Is there an object around the generator that will prevent operation or create a danger?
- Is proper air circulation ensured where the generator is installed?
- Are the ventilation ducts properly connected?
- Is the exhaust system connected correctly?
- Is the engine oil, coolant level appropriate?
- Is there enough fuel in the fuel tank for the first start-up?
- Are the battery pole heads connected correctly?
- Are both battery voltages above 12.5V?
- Is the power cable section used suitable for the generator power and is the connections made correctly? Are the control cables connected correctly?
- Are the mains and generator transfer panel connected correctly? Is the generator grounding done properly?
- Are the engine block heater and battery charge rectifier connected correctly?

11.2 Post Operation Controls

- Is there any abnormal sound or vibration?
- Is there a gas leak in the exhaust system
- Is there a leak of oil, fuel or water?
- Is air circulation appropriate in air shot and suction?
- Are the oil pressure and temperature values appropriate?
- Is the fuel system ventilated?
- Is the charging voltage value above 13.7V for generators with an electrical system of 12V and 27.6V for generators with a 24V system?
- Is the phase order correct when generator energy is available?
- Is the generator voltage and frequency appropriate?
- Is the heat appropriate when the load is gradually increased?

11.3 Periodic Maintenance to be Performed

Daily Checks (Pre-Start-up)

The amount of cooling water in the radiator is checked. If necessary, water is completed. The radiator is not filled up to the water throat, it is filled to 2-2.5cm below the surface of the upper chamber. That is, space is left in the radiator for evaporating water. Before the cold weather begins, the amount of antifreeze is checked and as much antifreeze is added as necessary.

The amount of oil is checked by pulling the dipstick. It should be between the two lines on the dipstick. If it is missing, the oil is put through the throat of the filling throat from the same oil as in the engine. After waiting for 15 minutes, the oil level is checked again. When the engine is started, the oil pressure is checked from the oil lamp on the switchboard (the oil lamp lights up when the oil pressure drops below its recommended value). It should not be below the recommended value. The amount of fuel in the tank is checked. Prevent the engine from landing at a level that will make air.

11.3.1 First Maintenance (50 hours)

All the procedures performed in daily care are repeated. The fuel filter element is replaced.

Important note: Replacing the fuel filter element should not be neglected. Otherwise, the fuel pump will fail. The oil filter and other filters (water, turbo, etc.) are replaced. The electrolytic level of the accumulator is checked, if it is missing, pure water is added. If the cell cover holes are dirty, they are cleaned.

Only pure water is put in the accumulator. Absolutely acidic water is not put. The water placed should be filled up to 1 cm above the plates, absolutely not up to the throat.

11.3.2 6 months or "250 Hours" Maintenance

All of the procedures performed in monthly or "50" hours of maintenance are repeated. Lubricating oil is changed. The oil filter element is replaced. Dry type air filter with paper element is replaced. The drive belt tearing and tensioner are checked. If necessary, the gap is removed by stretching. Fuel, lubrication system leaks are checked.

11.3.3 Annually or "750 Hours" Maintenance

All of the procedures performed in six months or "250" hours of maintenance are repeated. The cylinder head bolts and nuts are tightened and checked. Valve adjustment openings are checked and adjustments are made if necessary. The water in the cooling system is completely drained and new antifreeze is placed. The oil pressure is controlled by starting the engine. Alternator and starter connections are checked. It is checked whether all indicators are fully functioning. The injectors are removed, cleaned with kerosene oil and replaced by checking their settings.

11.3.4 Every "1250 Hours" Maintenance

All "750" hours of maintenance are repeated. Injector and valve settings are checked and necessary settings are made. The cooling water system is checked and the necessary cleaning procedures are performed. Check the starter and charging alternator. Check and tighten the mounting bolts and nuts.

11.3.5 Every "2500 Hours" Maintenance

All "1250" hours of maintenance are repeated. Cooling water is replaced with clean water and antifreeze is placed. Leak control and fasteners are checked. The radiator cores are cleaned and removed if there is any trapped air in the system.

Attention: If your generator is loaded under the specified conditions and the maintenance is carried out in accordance with the guideline and provided that maintenance and repair or other operations have not been carried out outside the technical service personnel authorized by KOCSAN Generator, it is fully covered by the warranty for 1 (one) year or 500 working hours (whichever expires first) against material, workmanship and production defects.

12. TERMS OF WARRANTY

1. The warranty period starts from the date of delivery of the goods and is 1 year for consumers. For the Merchants (customer) who use the goods for professional and commercial purposes, the warranty period is determined by the contract made between the companies.
2. All of the goods, including all parts, are covered by warranty.
3. If it is understood that the goods are defective, the consumer shall be liable to the following provisions in Article 11 of the Law on the Protection of Consumers No. 6502:
 - a. Withdrawal from the contract,
 - b. Requesting a discount from the sales price,
 - c. Request free repair,
 - d. Requesting that what is sold be replaced with a defective multiple can exercise one of its rights.
4. In the event that the consumer chooses the right to free repair from these rights, the seller; is obliged to make or have the goods repaired without any charge under any name such as labor costs, replacement parts or any other name. The consumer's right to free repair can also be exercised against the manufacturer or importer. The seller, producer and importer are jointly responsible for the exercise of this right by the consumer.
5. If the consumer exercises the right to free repair, the goods;
 - a. Re-failure within the warranty period,
 - b. Opening the maximum time required for its repair,
 - c. In cases where it is determined by a report by the authorized service station, the seller, the manufacturer or the importer that the repair is not possible;

The consumer may request the seller to refund the price of the goods, to reduce the price at the defective rate or, if possible, to replace the goods with a defect-free multiple. The seller cannot refuse the consumer's request. If this request is not fulfilled, the seller, manufacturer and importer are jointly responsible.

6. The repair period of the goods may not exceed 20 working days. This period starts on the date of notification of the defect of the goods to the authorized service station or dealer within the warranty period and from the date of delivery of the goods to the authorized service station if it is outside the warranty period. If the defect of the goods is not corrected within 10 working days, the manufacturer or importer; until the repair of the goods is completed, it is obliged to allocate another good with similar characteristics to the use of the consumer. In the event that the product fails within the warranty period, the time spent in the repair is added to the warranty period.

7. Defects caused by the use of the goods contrary to the issues in the user manual are out of

warranty.

8. In disputes that may arise regarding the exercise of the rights arising from the guarantee, the consumer may apply to the Consumer Arbitration Committee or the Consumer Court at the place of residence or where the consumer transaction is carried out.

9. If this Warranty Certificate is not issued by the seller, the consumer may apply to the General Directorate of Consumer Protection and Market Surveillance of the Ministry of Customs and Trade.

Note: During the Intervention of the Service, the customer must present a Certificate of Guarantee or Invoice.

13. EXCLUSIONS FROM WARRANTY

1. The commissioning of the purchased generators should be carried out by KOCSAN Generator authorized services and should not be made by the customers themselves or any other service. Otherwise, the generator is out of warranty. The commissioning process is valid only for the place where the operation is carried out and must be commissioned again by KOCSAN Generator authorized services for use in a new place. The customer will bear the cost of the commissioning process to be made for the second time.

2. All maintenance of all our generators within the warranty period, specified in the periodic maintenance schedule, must be carried out by the authorized services of KOCSAN Generator for a fee. If any of these maintenance is not done, the generator is out of warranty.

3. Failures caused by the use of materials not approved by KOCSAN Generator, failures caused by negligence, misuse, use of improper power, wrong placement, malfunctions arising from storage situations under inappropriate conditions and repair, maintenance and interventions by unauthorized services and persons are excluded from the scope of the generator warranty.

4. If the purchased generator will not be commissioned within 6 months, it should be kept on hold provided that the storage conditions of the generator are provided. In the event that the storage (conservation) process of a machine within the warranty period is carried out, the generator is out of warranty.

5. In on-board deliveries, it is the customer's sole responsibility to maintain the machine in appropriate conditions after delivery on the truck, including transport responsibility, unloading responsibility, until start-up. In case of damage and malfunctions that will occur during this time, the generator is out of warranty.

6.In the event that chemicals that should be added to the cooling system to prevent tingling, erosion and sediment are not added to the cylinder liner or block, the generator is out of warranty coverage due to the malfunctions that occur.

7. Within the warranty period, no additional equipment or project such as synchronous, additional control unit, panel, etc. can be made to the purchased generators except for the original equipment and project. If it is done without the approval of KOCSAN Generator, the generator is out of warranty.

8.In case of failures caused by environmental effects such as earthquakes, floods, floods, lightning strikes and similar natural disasters and the network, the generator is out of warranty.

9.KOCSAN Generator is not responsible for the failures that may arise from the drawing of more current than the generator rated current through the network contactor selected in accordance with the generator power.

10.The fuel used must have the characteristics given in the oil and cooling water usage manuals. Otherwise, in case of malfunctions and damages, the generator is out of warranty.

11.If the generator is not started for a long time, its battery may drain. In order for the engine to be lubricated, have a long service life and charge the battery, the generator must be started one day a week. Otherwise, the generator is out of warranty in case of malfunctions.

TEST-UV CERTIFICATE

EC DECLARATION OF CONFORMITY

Manufacturer :

Kocaeli Jeneratör Elektrik Makina San. Tic. Ltd. Şti.

Address :

Sanayi Mah. İzmit Sanayi Sitesi 13. Cad. 313. Blok No: 313 / 24
İzmit Kocaeli Turkey

Products :
Generators

Models :

KSP-B Series, KSP-D Series, KSY Series, KSR Series, KSS Series, KSB Series

Related Standards :

EN ISO 12100 Safety of machinery - General principles for design -
Risk assessment and risk reduction

EN 60204-1 Safety of machinery - Electrical equipment of machines -
Part 1: General requirements

EN ISO 8528-13 Reciprocating internal combustion engine driven alternating current
generating sets - Part 13: Safety

For the above products, the technical file and base product provided by the manufacturer is prepared on the basis of a voluntary test in accordance with the Machinery Safety Directive 2006/42/EC and Low Voltage Directive 2014/35/EU basic protection requirements.

The CE mark shown below can be used on the product at the discretion of the company, after the preparation of the necessary technical documents and declaration of conformity, and as long as other relevant directives and standards are complied with.

The use of CE marking is at the discretion of the company.

Certificate Publication Date: 10.03.2022

Certificate Expiry Date: 09.03.2023

Certificate Number: 21102350

TEST-UV Director



UNICERT



QUALITY MANAGEMENT SYSTEM CERTIFICATE

Universal GmbH

This certificate is granted to the organization,

Kocaeli Jenerator Elektrik Makina San. Tic. Ltd. Sti.

Sanayi Mah. Izmit Sanayi Sitesi 13. Cad. 313. Blok No:24
Izmit / Kocaeli / Turkey

by review of IA2.009538 numbered report for the scope

**Manufacture of Generator, Electrical Panel; Sales and
Technical Service Provision for Alternators,
Sound and Isolation Cabinets**

to certify that a management system in accordance with
standard's clauses is established and being implemented

DIN EN ISO 9001:2015

Certificate No : QMS 0322 009538

Original Certification Date : 2022 - 03 - 02

Issue / Revised Date : 2022 - 03 - 02

Expiry Date : 2023 - 03 - 01

Certification Period : 3 Years (1st Year)



Deutsche
Akkreditierungsstelle
D-ZM-16058-01-00

Universal GmbH



The authenticity of this certificate can be confirmed online or by e-mail to the Head Office via:

UNICERT



ENVIRONMENTAL MANAGEMENT SYSTEM CERTIFICATE

Universal GmbH

This certificate is granted to the organization,

Kocaeli Jenerator Elektrik Makina San. Tic. Ltd. Sti.

Sanayi Mah. Izmit Sanayi Sitesi 13. Cad. 313. Blok No:24
Izmit / Kocaeli / Turkey

by review of IA2.009538 numbered report for the scope

**Manufacture of Generator, Electrical Panel; Sales and
Technical Service Provision for Alternators,
Sound and Isolation Cabinets**

to certify that a management system in accordance with
standard's clauses is established and being implemented

DIN EN ISO 14001:2015

Certificate No : EMS 0322 009538

Original Certification Date : 2022 - 03 - 02

Issue / Revised Date : 2022 - 03 - 02

Expiry Date : 2023 - 03 - 01

Certification Period : 3 Years (1st Year)



Deutsche
Akkreditierungsstelle
D-ZM-16058-01-00

Universal GmbH



The authenticity of this certificate can be confirmed online or by e-mail to the Head Office via:

UNIVERSAL GmbH • Wilfried-Diekmann-Str. 20b 44536 Lünen Germany • T: +49 (0) 231 9931 9960 • info@uni-cert.de • www.uni-cert.de

CERTIFICATE

Nr: W-220220-O

**Kocaeli Jeneratör Elektrik Makina San.
Tic. Ltd. Şti.**

**Sanayi Mah. İzmit Sanayi Sitesi 13. Cad. 313. Blok No: 313 / 24 İzmit
Kocaeli Türkiye Turkey**

The certificate is issued for the above-mentioned company, according to the following scope given by the WQR Certification.

Bu sertifika yukarıda adı geçen firmaya, aşağıda belirtilen kapsamda WQR Belgelendirme tarafından verilmiştir.

ISO 45001:2018

Occupational Health and Safety Management System / İş Sağlığı ve Güvenliği Yönetim Sistemi

Scope of Certification / Belgelendirme Kapsamı

Generator, Alternator, Sound and Isolation Cabinet, Panel Manufacturing Sales and Service

Jeneratör, Alternatör, Ses ve izolasyon Kabini, Pano İmalatı Satışı ve Servis Hizmetleri

Release Date / Yayın Tarihi
22.02.2022

Last Issue Date / Son Basım Tarihi
22.02.2022

Expiry Date / Geçerlilik Tarihi
21.02.2025

Period Exp. Date / Bitiş Tarihi
21.02.2025

DIRECTOR

WQR International Certification Ltd.
www.wqrcert.com | info@wqrcert.com



CERTIFICATE

Nr: W-220220

**Kocaeli Jeneratör Elektrik Makina San.
Tic. Ltd. Şti.**

**Sanayi Mah. İzmit Sanayi Sitesi 13. Cad. 313. Blok No: 313 / 24 İzmit
Kocaeli Türkiye**

The certificate is issued for the above-mentioned company, according to the following scope given by the WQR Certification.

Bu sertifika yukarıda adı geçen firmaya, aşağıda belirtilen kapsamda WQR Belgelendirme tarafından verilmiştir.

ISO 10002:2018

Customer Satisfaction Management System / Müşteri Memnuniyeti Yönetim Sistemi

Scope of Certification / Belgelendirme Kapsamı

Generator, Alternator, Sound and Isolation Cabinet, Panel Manufacturing Sales and Service

Jeneratör, Alternatör, Ses ve İzolasyon Kabini, Pano İmalatı Satış ve Servis Hizmetleri

Release Date / Yayın Tarihi
22.02.2022

Last Issue Date / Son Başım Tarihi
22.02.2022

Expiry Date / Geçerlilik Tarihi
21.02.2023

Period Exp. Date / Bitiş Tarihi
21.02.2025

DIRECTOR

WQR International Certification Ltd
www.wqrcert.com | info@wqrcert.com





HİZMET YETERLİLİK BELGESİ

Belge No	:34-HYB-15323
İlk Veriliş Tarihi	:27.01.2016
Son Geçerlilik Tarihi	:27.01.2023
Firmanın Adı	:KOCAELİ JENERATÖR ELEKTRİK MAKİNA SANAYİ TİCARET LİMİTED ŞİRKETİ
Firmanın Adresi	:SANAYİ MAH. İZMİT SANAYİ SİTESİ 2. CAD. NO:3 /6 İZMİT KOCAELİ/TÜRKİYE
Hizmet Yeri Adresi	:SANAYİ MAH. İZMİT SANAYİ SİTESİ 13. CAD. 313. BLOK NO: 313 İÇ KAPI NO: 24 İZMİT KOCAELİ KOCAELİ/TÜRKİYE
Sicil No	:24943

Verilen Hizmetin Kapsamı

1. TS 12650 (18.02.2016) YETKİLİ SERVİSLER - İÇTEN YANMALI MOTORLAR TARAFINDAN TAHRİK EDİLEN JENERATÖRLER - KURALLAR STANDARDINA UYGUN HİZMET VEREN

- * EMSA ELEKTROMOTOR ALTERNATÖR SANAYİ VE TİCARET A.Ş. YETKİLİ SERVİSİ (433875) (27.01.2016) (EMSA) MARKALI
- * GÜÇBİR JENERATÖR SANAYİ TİCARET LTD. ŞTİ. YETKİLİ SERVİSİ (1188471) (06.02.2017) (GÜÇBİR JENERATÖR) MARKALI
- * İNDEKS ELEKTRİK ELEKTRONİK MAKİNA İNŞAAT VE MALZEMELERİ TURİZM OTOMOTİV NAKLİYAT DENİZ ARAÇLARI SANAYİ VE TİCARET A.Ş. YETKİLİ SERVİSİ (1100406) (06.02.2017) (İNDEKS) MARKALI
- * MAKELSAN MAKİNE KİMYA ELEKTRİK SANAYİ VE TİCARET ANONİM ŞİRKETİ YETKİLİ SERVİSİ (1084939) (17.01.2020) ((MAKELSAN JENERATÖR)) MARKALI
- * REİS MAKİNA TİCARET VE SANAYİ ANONİM ŞİRKETİ YETKİLİ SERVİSİ (321500) (17.01.2020) ((FULL JENERATÖR],[KİPÖR],[KAMA BY REİS]) MARKALI

Türk Standardları Enstitüsü Hizmet Belgeleme Yönergesine göre yapılan inceleme neticesinde; firma işyerinin, kapsamında belirtilen, hizmetler için yeterli olduğu tespit edilerek bu belge verilmiştir.

e-İmza/İmza

22.02.2022

METİN İNAL

ANADOLU YAKASI HİZMET YERİ BELGELENDİRME MÜDÜRÜ



TSE Kalite Kampüsü Cumhuriyet Mah. 2258 Sk. No:10 A-Blok, Çayırova Tren İstasyonu Yanı Gebze-KOCAELİ Telefon: 262 7231313 Faks: 262 7231616

Bu belge hiçbir suretle tahrif edilmez, kısmen veya okunmasını zorlaştıracak şekilde çoğaltılamaz, kopyasını ve silini yapılamaz. Sayfa : 1 / 1

<https://evrakkontrol.tse.org.tr/BelgeDogrulama.aspx?p=tnquödes> adresinden belgenin doğruluğunu ve geçerliliğini sorgulayınız.

Firmaya ait diğer şube bilgilerinizi <https://buavuraportal.tse.org.tr/GenelFirmaArama.aspx> adresinden sorgulayabilirsiniz.



T.C. TİCARET BAKANLIĞI

TÜKETİCİNİN KORUNMASI VE PİYASA GÖZETİMİ GENEL MÜDÜRLÜĞÜ

SATIŞ SONRASI HİZMET YETERLİLİK BELGESİ

Belgenin Veriliş Tarihi ve
Sayısı: 06.04.2022 / 62028

Belgenin Geçerlilik Tarihi: 06.04.2024

İmalatçı ve İthalatçı Firmamız

Ünvanı : KOCAELİ JENERATÖR ELEKTRİK MAKİNA SANAYİ TİCARET LİMİTED
ŞİRKETİ -
Merkez Adresi : SANAYİ MAH. İZMİT SANAYİ SİTESİ 13. CAD. 313. BLOK NO: 313 İÇ KAPI
NO: 24 İZMİT KOCAELİ KOCAELİ
Verilen Hizmetin Kapsamı : TS 12650 Yetkili servisler - İçten yanmalı motorlar tarafından tahrik edilen
jeneratörler - Kurallar

Bu belgenin kullanılmasına; 6502 sayılı Tüketicinin Korunması Hakkında Kanun uyarınca, T.C. Ticaret
Bakanlığı Tüketicinin Korunması ve Piyasa Gözetimi Genel Müdürlüğü tarafından izin verilmiştir.

Mehmet ÖZBOLAT
Bakan a.
Daire Başkanı V.

